



Limiting Conditions

Body design conditions	PN40
Maximum allowable pressure (PMA)	40 bar g @ 100 °C
Maximum allowable temperature (TMA)	300 °C @ 27.5 bar g
Maximum operating pressure (PMO)	32 bar g
Maximum operating temperature (TMO)	285 °C
Cold hydraulic test pressure	38 bar g

Materials

NO.	Part	Material
1	Body	Carbon Steel
2	Baffle Plate	Carbon Steel
3	Support Bracket	Carbon Steel
4	Reinforced Plate	Carbon Steel

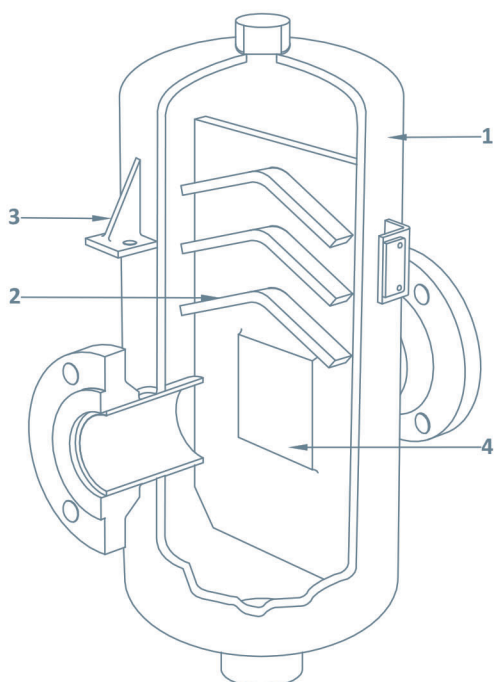

Description

The SSEP40 is a baffle-type separator which has fully steel-made construction, used for the removal of entrained liquids in high pressurized steam or air & gas systems, so that they can be drained away as condensate.

Fluids handled

Saturated steam
Compressed air
Gas system

Sizes and connections

Flanged – PN40 DN100 to DN200
Note: larger sizes and different flange rating are available, on request.

Dimensions and weights (mm and kg)

Size (DN)	L	H	H1	H2	E	F	Weight
100	574	795	337	180	2"	3/4"	83
125	656	843	310	247	2"	3/4"	118
150	706	935	347	273	2"	3/4"	154
200	858	1200	460	372	2"	2"	292

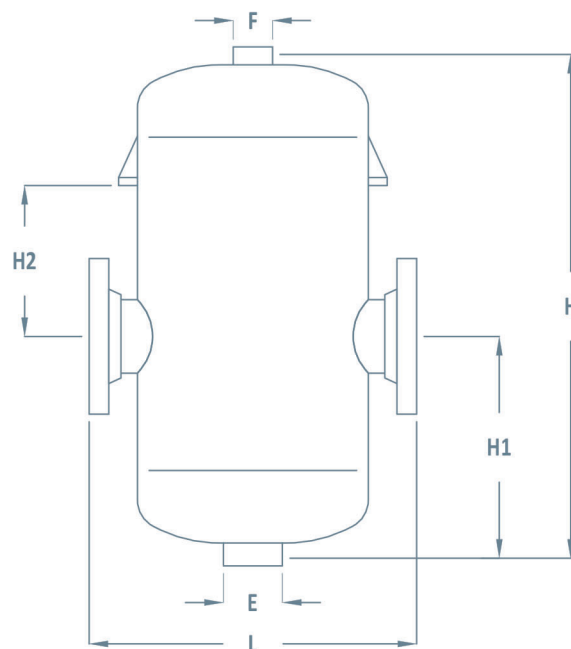

Safety information, installation and maintenance

The SSEP40 is a reliable, efficient and free-maintenance separator, must be installed in a horizontal pipeline with the drain directly below. To ensure that any separated liquid is drained away quickly, a suitable liquid drainer/steam trap must be connected to the drain connection 'E'. Moreover, a thermostatic air vent at the top connection 'F' can provide air venting from the system.

*For full details see the Installation and Maintenance Instructions, supplied with the product.